

PCT

WORLD INTELLECTUAL PROPERTY ORGANIZATION
International Bureau



INTERNATIONAL APPLICATION PUBLISHED UNDER THE PATENT COOPERATION TREATY (PCT)

<p>(51) International Patent Classification ⁵ : A61L 15/44</p>	<p>A1</p>	<p>(11) International Publication Number: WO 90/07939 (43) International Publication Date: 26 July 1990 (26.07.90)</p>
<p>(21) International Application Number: PCT/US90/00241 (22) International Filing Date: 10 January 1990 (10.01.90) (30) Priority data: 295,788 11 January 1989 (11.01.89) US (71) Applicant: NOVEN PHARMACEUTICALS, INC. [US/US]; 13300 S.W. 128th Street, Miami, FL 33186 (US); (72) Inventors: SABLOTSKY, Steven ; 9245 S.W. 118th Terrace, Miami, FL 33176 (US). GENTILE, Cheryl, M. : 5751 Rose Terrace, Plantation, FL 33317 (US). (74) Agent: MELOY, Sybil Ruden, Barnett, McClosky, Smith, Schuster & Russell; 701 Brickell Avenue, Suite 1900, Miami, FL 33131 (US).</p>	<p>(81) Designated States: AT, AT (European patent), AU, BE (European patent), BG, BR, CA, CH, CH (European patent), DE, DE (European patent), DK, DK (European patent), ES, ES (European patent), FI, FR (European patent), GB, GB (European patent), HU, IT (European patent), JP, KR, LU (European patent), NL, NL (European patent), NO, RO, SE, SE (European patent), SU.</p> <p>Published <i>With international search report. Before the expiration of the time limit for amending the claims and to be republished in the event of the receipt of amendments.</i></p>	
<p>(54) Title: BREATHABLE BACKING</p> <p>(57) Abstract</p> <p>A composition comprising a flexible backing for a transdermal drug preparation with a water vapor transmission rate about equal to or in excess of that of ethylene vinyl alcohol copolymer, namely equal to or in excess of, at one mil thickness, of about 2 to 4 grams and more preferably in excess of 6 grams per 24 hours per 100 square inches at 40°C and 90 % relative humidity and an oxygen transmission rate equal to or less than ethylene vinyl alcohol copolymer, namely at one mil thickness equal to or less than about 0.01 to 0.1 cubic centimeters per 100 square inches measured over 24 hours at 1 atmospheric pressure, 20°C and 65 % relative humidity.</p>		

FOR THE PURPOSES OF INFORMATION ONLY

Codes used to identify States party to the PCT on the front pages of pamphlets publishing international applications under the PCT.

AT	Austria	ES	Spain	MG	Madagascar
AU	Australia	FI	Finland	ML	Mali
BB	Barbados	FR	France	MR	Mauritania
BE	Belgium	GA	Gabon	MW	Malawi
BF	Burkina Faso	GB	United Kingdom	NL	Netherlands
BG	Bulgaria	HU	Hungary	NO	Norway
BJ	Benin	IT	Italy	RO	Romania
BR	Brazil	JP	Japan	SD	Sudan
CA	Canada	KP	Democratic People's Republic of Korea	SE	Sweden
CF	Central African Republic	KR	Republic of Korea	SN	Senegal
CG	Congo	LI	Liechtenstein	SU	Soviet Union
CH	Switzerland	LK	Sri Lanka	TD	Chad
CM	Cameroon	LU	Luxembourg	TG	Togo
DE	Germany, Federal Republic of	LV	Luxembourg	US	United States of America
DK	Denmark	MC	Monaco		

BREATHABLE BACKING

This application is a continuation in part of U.S. Patent Application Serial Number 164,482, filed March 4, 1988, now under U.S. Patent Number _____, granted _____, which Application Serial Number 164, 482 is incorporated herein by reference. Applications are assigned to Noven Pharmaceuticals, Inc. of Miami, Florida.

BACKGROUND OF THE INVENTION

This invention relates to a flexible backing for a composition for administration of drugs through the skin.

With increasing frequency, pharmacologically active agents have been administered by application to the skin, often in a solid carrier. The drug is incorporated into the carrier and attached to the skin, typically by means of an adhesive. The carrier can be a gel or a more rigid polymer or combination of polymeric substances and can have single or multiple components. The adhesive can also function as the carrier. One side of the carrier is applied to the skin, while the other side is accessible to the environment.

Typically, a backing is present on the side of the carrier accessible to the environment. The backing limits the passage of substances from the carrier into the environment, and limits the reverse passage of substances from the environment into the carrier. Typically, the backings are composed of metal foil, metallized plastic, or single or multiple layers of a polymeric (plastic) substances which do not permit the passage of more than negligible amounts of water.

One known carrier, namely the Bolar Pharmaceutical Co. transdermal preparation for

SUBSTITUTE SHEET

nitroglycerin sold under the trademark NTS, contains a backing material containing polyvinyl chloride. Other backing materials used in transdermal preparations marketed in the United States include aluminized polyester (Transderm Scopolamine, CIBA); other aluminized plastics are used in Transderm Nitro (CIBA); Deponit (Wyeth); and Catapress-TTS (Boehringer Ingelheim.). Aluminum foil (Nitro-Dur, Key; Nitrodisc, Searle), polyethylene/polyvinylidene chloride coextrusion (Nitro-Dur II, Key), and polyester (Estraderm, CIBA) are also used.

Aluminum containing backing materials have negligible moisture vapor transmission rates. Aluminum foil, as reported in "Aluminum Foil" by the Aluminum Association, Inc., page 5, Table 3, Second Edition, January 1981, is impermeable to moisture at a thickness of one mil (0.001 inch) and thicker. The water vapor transmission rate is 0.02 grams or less/100 square inches in 24 hours at 100 degrees Fahrenheit (°F) for a foil of 0.00035 inches, a commonly used thickness. When 0.00035 inch foil is laminated, the water vapor transmission rate drops to practically zero.

Other films common to the film industry, not necessarily to transdermals, which in principle are applicable to transdermals are polyethylene and ethylene copolymers, linear low density polyethylene, very low density polyethylene, ethylene methyl acrylate, ethylene vinyl acetate, polypropylene, polystyrene, polyurethane, polyvinyl and vinyl copolymers, and vinylidene chloride polymers and copolymers (Sarans).

Other available plastic films include:

Acetal

Acrylic

Acrylonitrile Butadiene Styrene (ABS)
Acrylonitrile (Methyl Methacrylate/MMA)
Copolymer
Acrylonitrile Copolymer, Biaxially-Oriented
Acrylonitrile Types, Other
Ethylene Ethyl Acrylate (EEA)
Ethylene Methyl Acrylate (EMA)
Ethylene Vinyl Acetate (EVA)
Ethylene Vinyl Acetate (EVA) Copolymer
Ethylene Vinyl Alcohol (EVOH) Polymer
Ionomers
Nylon (Polyamide)
Nylon (Polyamide), Biaxially-Oriented
Nylon (Polyamide), Monoaxially-Oriented
Nylon (Polyamide) Copolymer
Polybutylene (PB)
Polycarbonate (PC)
Polyester
Polyester, Oriented
Polyester, Thermoplastic (Polyethylene
Terephthalate) (PET)
Polyester, Thermoplastic Copolymer (PET-G)
Polyethylene, High Density (HDPE)
Polyethylene, High Density (HDPE), Oriented
Polyethylene, High-Molecular-Weight, High
Density (HMWHDPE)
Polyethylene, Intermediate-Molecular-Weight,
High Density (IMWHDPE)
Polyethylene, Linear Low Density (LLDPE)
Polyethylene, Low Density (LDPE)
Polyethylene, Medium Density (MDPE)
Polyethylene Oxide
Polyimide
Polypropylene (PP)
Polypropylene (PP), Coated

SUBSTITUTE SHEET

Polypropylene, Oriented (OPP)

Polystyrene (PS)

Polyurethane (PU)

Polyvinyl Acetate (PVAC)

Polyvinyl Chloride (PVC)

Polyvinylidene Chloride (PVDC)

Styrene Acrylonitrile (SAN)

Backings previously used for transdermal compositions typically consist of a polymer alone or laminated to a metal foil which is substantially impervious to moisture and gas, and thus not "breathable" in the sense of permitting permeation of water vapor to and from the composition. The result of this lack of breathability is a tendency of the formulation to irritate the skin or to tend to detach from the skin or both.

The backing must be sufficiently flexible to permit movement of the skin and be compatible with the carrier and drug in the sense that the carrier or the drug does not substantially degrade the backing, especially under normal conditions of use and storage for one to two years. The backing should also not substantially degrade the drug or the carrier.

The general theory of permeation of a gas or a liquid through a polymer matrix is that permeation is a product of the diffusion time and solubility constant of the permeant in the polymer matrix, both of which are often independent of each other. Very often, the property which results in a good gas barrier results in a poor water barrier. For example, highly polar polymers such as those containing hydroxyl groups (ethylene vinyl alcohol) are excellent gas barriers but poor water barriers. Conversely, non-polar hydrocarbon polymers such as polyethylene have excellent water barrier properties but poor gas barrier properties.

SUBSTITUTE SHEET

In order to be a good barrier polymer, the material should have some degree of polarity, chain stiffness, inertness, close chain-to-chain packing, some bonding or attraction between chains and a high glass transition temperature (T_g). The various types of barrier polymers and their uses are thoroughly discussed in Salame, et al., "Barrier Polymers", Polym.-Plast. Technol. Eng. 8(2), 155-175 (1977). Not only does the functional group have an effect on oxygen permeability, but so does the degree of crystallinity, the degree of orientation of polymer chains, the inclusion of fillers and additives and the presence of moisture in the polymer. As a rule of thumb, permeation increases by 30 to 50% for every 5 degrees Celsius (C°) temperature rise. Rate of permeation is also affected by the molecule, the molecular shape and the polarity of the permeating species.

SUMMARY OF THE INVENTION

It has now been found that a backing for use with a transdermal composition can be constructed such that not only is the backing compatible with the drug/carrier composition and the drug/carrier composition is compatible with the drug, but the backing permits the passage of water vapor without permitting the passage of the drug or gases from the composition or the entry of gases or liquids from the environment.

The backing material of this invention comprises at least one, and can contain two or more layers. At least one layer of the backing is a membrane which is compatible with the drug chosen and with which the drug is compatible, is flexible, and has a water vapor transmission rate about equal to or in excess of that of ethylene vinyl alcohol copolymer

(EVOH) of about 0.2 to 3 mil thickness. EVOH at 1 mil thickness has a water vapor transmission rate in excess of about 2 to 4 g/100 square inches (in²) per 24 hours, at 40°C and 90% relative humidity (RH).

The backing also should have an oxygen transmission rate about equal to or less than that of EVOH of about 0.2 to 3 mil thickness. EVOH at 1 mil thickness has an oxygen transmission rate of about 0.01 to 0.1 cubic centimeters per 100 square inches measured over 24 hours at one atmosphere pressure, at 20°C and 65% relative humidity.

The additional layers of the breathable backing have water vapor transmission rates equal to or in excess of that of EVOH of 0.2 to 3 mil thickness, more preferably in excess of about 6 grams and even more preferably in excess of about 9 grams per 100 in² per 24 hours at 40°C and 90% RH.

Some of the backing materials of this invention, for example nylon/ethylene vinyl alcohol/polyethylene coextrusions have been used in high barrier food packaging applications. In those compositions, the nylon and polyethylene tend to reduce the adverse effect of moisture on the very low gas transmission properties of EVOH, while enhancing flex crack-resistance, strength and toughness of the composition, to result in a clear film having low gas barrier properties throughout the range of relative humidity found in ambient conditions of food storage.

BRIEF DESCRIPTION OF THE DRAWING

Fig. 1 is a cross-section of the transdermal composition having the backing material of this invention.

DETAILED DESCRIPTION OF THE INVENTION

A composition for the administration of drugs through the skin comprising a pharmacologically

active agent in a transdermal carrier, namely one suitable for transdermal administration, and a backing for the carrier.

The backing comprises at least one layer, said primary layer having a high water vapor transmission rate and a moderate to low gas transmission rate. Thus the backing has a water vapor transmission rate about equal to or in excess of that of ethylene vinyl alcohol copolymer (EVOH) and a gas transmission rate about equal to or less than EVOH, in which the EVOH is of about 0.2 to 3 mil thickness. The backing can comprise additional polymeric layers, for example, a second layer having a high water vapor transmission rate, as well as additional layers. The additional layers can be placed on one or both sides of the first layer.

Basically, the backing material is constructed of a barrier polymer or resin or other permeable material. The term "barrier" is used here in reference to a material's resistance to absorption, diffusion, and desorption of gases, moisture and other chemicals. By the use of certain barrier materials, a film can be made selectively permeable to water or other liquid vapor rather than gas or vice versa.

The permeability to gas and moisture vapor is known or can be computed using standardized tests. A comparison of different plastics is found in "Barrier Resins Key New Package Development", *Plastics Packaging*, July/August 1988, pp. 17-21.

Table 1
Comparison of Barrier Properties
for Commercial polymers

	Moisture Vapor	
	Oxygen Transmission Rate, 25°C, 65/RH (cc-mil/100 in ² -24 hours)	Transmission Rate, 40°C, 90/RH (cc-mil/100 in ² -24 hours)
Ethylene		
vinyl alcohol	0.05 to 0.18	1.4 to 5.4
Polyvinylidene chloride	0.15 to 0.90	0.1 to 0.2
Acrylonitrile	0.80	5.0
Amorphous nylon	0.74 to 2.0	
Oriented poly- ester terephthalate	2.60	1.2
Oriented nylon	2.10	9.0
Rigid polyvinyl chloride	14.0	3.0
Low density polyethylene	420	1.0 to 1.5
High density polyethylene	150	0.4
Polypropylene	150	0.69
Polystyrene	350	7 to 10

In the above table, oxygen transmission rate is expressed in cubic centimeters of oxygen of 1 mil film per 100 square inches surface area per 24 hours at 65% relative humidity (RH) and 25° Celsius (°C) and moisture vapor transmission rate is expressed in cubic centimeters per 100 square inches of surface area of 1 mil film per 24 hours at 40 degrees Celsius (°C) and 90% relative humidity.

Additional moisture vapor transmission rates, reported in the EVALCA bulletin number 110, are:

Table 2

Moisture Vapor Transmission Rate

(40°C, 90%R.H.)

<u>Material</u>	g. 30microns/ m ² /24 Hrs.	g.mil/100 in ² /24 Hrs.
Biaxially Oriented		
Polypropylene	5	0.38
High Density		
Polyethylene	5	0.38
Polypropylene	9	0.69
Low Density		
polyethylene	15	1.14
Biaxially Oriented		
Polyester		
Terephthalate	15	1.2
Rigid Polyvinyl		
Chloride	40	3.1
Polystyrene	112	8.5
Biaxially Oriented		
Nylon 6	134	10.0
Polycarbonate	14.5	1.1
EVAL EP-F	50	3.8
EVAL EP-H	28	2.1
EVAL EP-K	28	2.1
EVAL EP-E	19	1.4
EVAL EP-G	19	1.4
Saran 5253 PVC	3	0.22
Barex 210 Nitrile	80	6.1

In the above table in² refers to square inches and m² to square meters.

The backing should:

1. Maintain its physical and chemical integrity in the environment of use;
2. Provide mechanical support for the other laminae forming a laminate carrier;
3. Be substantially impermeable to the pharmacological agent;
4. Be selectively permeable to the passage of internal water vapor; and
5. Be substantially impermeable to gases to water or moisture but permeable to water vapor.

The molecular weight of the polymers selected for the backing are such that the backing has the foregoing characteristics and the layers, the indicated water vapor and oxygen transmission rates.

The term "pharmacologically active agent" or "drug", as used herein, means and refers to any substance capable of being administered to the skin of an animal to exert a local or systemic effect. Currently, nitroglycerin, estradiol, scopolamine and clonidine are available commercially in transdermal formulations. However, in theory, any drug is capable of being used locally or systemically by application to the skin. Thus, the term "pharmaceutically active agent" can include, but is not limited to:

1. Anti-infectives, such as antibiotics, including penicillin, tetracycline, chloramphenicol, sulfacetamide, sulfamethazine, sulfadiazine, sulfamerazine, sulfamethizole and sulfisoxazole; antivirals, including idoxuridine; and other anti-infectives including nitrofurazone and the like;
2. Anti-allergens such as antazoline, methapyrilene, chlorpheniramine, pyrilamine and prophenpyridamine;

SUBSTITUTE SHEET

3. Anti-inflammatories such as hydrocortisone, cortisone, dexamethasone, fluocinolone, triamcinolone, medrysone, prednisolone, and the like;
4. Decongestants such as phenylephrine, naphazoline, and tetrahydrozoline;
5. Miotics and anticholinesterases such as pilocarpine, carbachol, and the like;
6. Mydriatics such as atropine, cyclopentolate, homatropine, scopolamine, tropicamide, ecuatropine and hydroxyamphetamine;
7. Sympathomimetics such as epinephrine;
8. Beta-adrenergic agents such as salbutamol and terbutaline.
9. Sedatives, hypnotics and anesthetics such as chloral, pentobarbital, phenobarbital, secobarbital, codeine, (alpha-bromoisovaleryl) urea, lidocaine, fentanyl and fentanyl analogs, opiates, opioids, agonists and antagonists therefor;
10. Psychic energizers such as 3(2-aminopropyl)indole, 3(2-aminobutyl) indole, and the like;
11. Tranquilizers such as reserpine, chlorpromazine, thiopropazate and benzodiazepines such as alprazolam, triazolam, lorazepam and diazepam;
12. Androgenic steroids such as methyltestosterone and fluoxymesterone;
13. Estrogens such as estrone, 17-beta-estradiol, ethinyl estradiol, and diethylstilbestrol;
14. Progestational agents, such as progesterone, 19-norprogesterone, norethindrone, megestrol, melengestrol, chlormadinone, ethisterone, medroxyprogesterone, norethynodrel and 17 alpha-hydroxyprogesterone;

15. Humoral agents such as the prostaglandins, for example PGE₁, PGE₂alpha, and PGF₂alpha;

16. Antipyretics such as aspirin, salicylamide, and the like;

17. Antispasmodics such as atropine, methantheline, papaverine, and methscopolamine;

18. Anti-malarials such as the 4-aminoquinolines, alpha-aminoquinolines, chloroquine, and pyrimethamine;

19. Antihistamines such as diphenhydramine, dimenhydrinate, perphenazine, and chloropenazine;

20. Cardioactive agents such as nitroglycerin, isosorbide dinitrate, isosorbide mononitrate, quinidine sulfate, procainamide, benzydroflumethiazide, flumethiazide, chlorothiazide, calcium antagonists such as nifedipine, verapamil and diltiazem and selective and non-selective beta blockers such as timolol and propranolol, ACE inhibitors such as captopril and various other agents such as clonidine and prazosin.

21. Nutritional agents such as essential amino acids and essential fats.

Other drugs having the same or different physiological activity as those recited above can be employed in drug delivery devices within the scope of the present invention.

Drugs, contained in the carrier, can be in different forms, such as uncharged molecules, components of molecular complexes or pharmacologically acceptable salts or derivatives thereof. Simple derivatives of the drugs such as pharmaceutically acceptable ethers, esters, amides, and the like which have desirable retention and release characteristics but which are easily

hydrolyzed at body pH, enzymes, pro-active forms, and the like can be employed.

The dosage unit amount for conventional beneficial drugs as set forth herein, in the accompanying disclosure and examples, is also known to the art in standard reference books such as Remington's Pharmaceutical Sciences, Seventeenth Edition, Part IV, 1970, published by Mack Publishing Co., Easton, Pennsylvania and Goodman and Gilman, "The Pharmacological Basis of Therapeutics", MacMillan Publishing Co., 6th Edition (1980).

"Transdermal carrier", as used herein, means and refers to any generally planar carrier suitable for containing a pharmaceutically active agent for transdermal administration having two surfaces, one surface being adapted for application to the skin and the second surface being opposed thereto. A great number of materials are known in the prior art for such uses. The nature of the material is not critical so long as the carrier permits release of the drug on to and through the skin, as in the case of transdermal administration. Typical transdermal carriers include pressure sensitive adhesives, such as polyacrylic acids, natural and synthetic rubbers, silicones, and polyvinyl acetates. One surface of the carrier is adapted for application to the skin. The other surface carries the backing material.

Suitable polymeric materials for the transdermal backing include acrylonitrile, cellulose acetate, polycarbonate, ethylene vinyl acetate, ethylene methyl acrylate, polyester, polyethylene, polypropylene, polystyrene, polyurethane, polyvinyl alcohol, ethylene vinyl alcohol, polyamides, polyvinylidene chloride and polyvinyl chloride. Some polymers increase barrier properties by orienting the polymer chains in one or two directions.

The backing material of this invention comprises at least one, and can contain two or more natural or synthetic polymeric layers. At least one layer of the backing is composed of a polymer which is compatible with the drug chosen and with which the drug is compatible, is flexible, and has a water vapor transmission rate equal to or greater than EVOH of 0.2 to 3 mil thickness, namely a rate equal to or in excess of about 2 to 4 grams/100 in² per 24 hours, at 40°C and 90% RH and more preferably 6 grams and an oxygen transmission rate equal to or less than EVOH of 0.2 to 3 mil thickness, namely of less than 0.01 to 0.1 cubic centimeters per 100 square inch when measured over 24 hours at one atmosphere pressure, 20°C and 65% relative humidity.

The backing can also have a second or additional layers composed of a polymer which is compatible with the drug chosen and with which the drug is compatible, is flexible, and has a water vapor transmission rate in excess of that of EVOH of 0.2 to 3 mil thickness, namely in excess of about 2 to 4 grams per 100 square inches per 24 hours, at 40°C and 90% relative humidity and preferably in excess of 6 grams.

The water vapor transmission rate of a given polymer is a function of the polymer and thus varies with the average molecular weight, configuration and orientation, chain length, nature of repeating units, the degree of crosslinking, the degree of crystallinity, the nature and extent of the monomer and the like, as well as time, temperature, relative humidity and thickness of the film. The rate thus varies, not only from polymer to polymer, but to different types of a specific polymer.

The preferred polymers for the additional layers are those having the greater water vapor transmission rate, thus the preferred polymers are cellulose acetate, nylon, polycarbonate, acrylonitrile, polystyrene, polyurethane and polyvinyl alcohol, or copolymers or multipolymers of these plastics with additional monomers. Polyurethane is an especially preferred material for the secondary layer.

Thus, the breathable backing of this invention comprises at least one layer of a substance having a high water vapor transmission rate and a low gas transmission rate. These physical properties can be found in the highly polar polymers, such as those containing hydroxyl groups such as polyvinyl alcohol, and ethylene vinyl alcohol, see e.g., Barrier Polymers article, 1977, p. 156. More particularly, ethylene vinyl alcohol copolymer (EVOH) has a particularly low gas transmission rate.

The backing material can consist of a single layer having the indicated high water vapor transmission rate and low gas transmission rate. In addition, a single or multi-layered material can be used on one or both sides of the primary layer. These secondary layers need only have the high water vapor transmission rate and can be used to minimize potential degradation of the primary layer by the presence of air and moisture. The substances selected for additional polymeric layers can be the same or of different polymers.

In general, the additional layers have a moisture vapor transmission rate in excess of that of EVOH of 0.2 to 3 mil thickness, namely in excess of about 2 to 4 grams per 100 square inches at 40°C, 90% relative humidity over 24 hours, and more preferably

in excess of about 6 grams per 100 square inch and more preferably in excess of 9 grams per 100 square inch.

The backing can be prepared by any of the methods used to join plastics in a film, including lamination or coextrusion. In the case of lamination, various means known in the art can be utilized to cause the layers to adhere.

Typically, each layer of the laminate is approximately 5 to 100 microns, and preferably 12 to 75 microns in thickness.

The preferred backing material for use in this invention is a layer of ethylene vinyl alcohol copolymer laminated or coextruded with polyurethane. An especially preferred backing material for use in this invention is one in which the polyurethane film is that available from JPS Elastomerics, 395 Pleasant Street, Northampton, MA 01061. The preferred ethylene vinyl alcohol copolymer is the polymer sold under the trademark "EVAL" item EF-F, available from EVAL Company of America, 1001 Warrenville Road, Suite 201, Lisle, Illinois 60532. The EF-F polymer has the following physical properties:

Item	Unit	Measuring Method	Measuring Condition	EF-F	Range For All EVALS
Thickness	Microns			15	12-25
Tensile strength, (Breaking)	kg/mm ²	JIS Z 7509	20°C 65%RH	9	7-21
Elongation, (Breaking)	MD %	JIS Z 7509	20°C 65%RH	4	4-20
Water vapor	g/in ²			140	100-190
Transmission rate	24 hrs	JIS Z 0208	40°C 90%RH	100	35-100
Water absorption Equilibrium	%		30°C 24 hrs	8.6	5.9-8.6
moisture absorption	%		20°C 65%RH	3.9	2.8-3.9
Dimensional stability under heat	MD %	140°C 1hr	-2.7	-0.9	(-1.6)-(-4.0)
Oxygen transmission rate	cc/m ² -24hrs-atm	JIS Z 1707	35°C 0%RH	0.5	0.4-3.2
			20°C 65%RH	0.5	0.3-1.5
			20°C 85%RH	2	1-3.3
Melting point	°C		20°C 100%RH	25	6-25
				181	164-181

17

In the foregoing table and elsewhere in this application, the following standard abbreviations are used: kilograms (kg), millimeters (mm), square millimeters (mm^2), grams (g), centimeters (cm), square centimeters (cm^2), cubic centimeters (cc), meters (m), square meters (m^2), percent (%), atmospheric pressure (atm), degrees Celsius ($^{\circ}\text{C}$), relative humidity (RH), machine direction (MD) and transverse direction (TD). JIS refers to Japanese Industrial Standards.

The layers are juxtaposed face to face, and are bonded to each other. They are sufficiently flexible to be able to adapt to the contour of the skin and movements therein.

It is known that the mole percent ethylene in an ethylene vinyl alcohol copolymer affects not only the oxygen transmission rate of the copolymer, but the sensitivity of that oxygen transmission rate to relative humidity. Thus, the lower the percentage of ethylene in ethylene vinyl alcohol copolymer, the lower the oxygen transmission rate. Thus, it has been reported that a 1.0 mil ethylene vinyl alcohol copolymer containing 29 mole percent ethylene has an oxygen transmission rate of less than 0.02 at 0% relative humidity and 68 $^{\circ}\text{F}$, and approximately 0.05 at 80% relative humidity. On the other hand, under the same conditions of relative humidity and temperature, ethylene vinyl alcohol copolymer containing 38 mole percent and 44 mole percent of ethylene has an oxygen transmission rate of about 0.06 to 0.07 at 0% relative humidity, rising to approximately 0.2% at 80% relative humidity. In contrast, a 1.0 mil nylon film has an oxygen transmission rate of just above 2 at relative humidities ranging from 0% to in excess of 80% at 73 $^{\circ}\text{F}$. Similarly, the coextrusion of an

ethylene vinyl alcohol copolymer and nylon tends to lower the oxygen transmission rate through a wide range of relative humidities, as compared with the non-coextruded ethylene vinyl alcohol copolymer.

The following examples illustrate the invention more fully without any intention of being limited thereby.

Backing Materials

EXAMPLE 1

A backing for a transdermal drug delivery system was prepared as follows: first, a 1.5 mil polyurethane was laminated to a 15 micron ethylene vinyl alcohol film with a polyurethane based adhesive using a Dru-Tec Laminator. Next, the remaining exposed ethylene vinyl alcohol film was laminated to a 1.0 mil polyurethane with a polyurethane based adhesive on the Dru-Tec Laminator.

EXAMPLE 2

Following the procedure in Example 1, a 1.5 mil polyurethane on both sides of the 15 micron ethylene vinyl alcohol film was prepared.

EXAMPLE 3

Following the procedure in Example 1, a 1.5 mil polyurethane on one side of the 15 micron ethylene vinyl alcohol film and a 1.0 mil nylon on the other side was prepared.

EXAMPLE 4

Following the procedure in Example 1, a 1.5 mil polyurethane on one side of the 15 micron ethylene vinyl alcohol film and 0.7 mil ethylene methyl acrylate on the other side was prepared.

Moisture Vapor Transmission Rate ("MVTR")
and Oxygen Transmission Rate ("OTR")
for Films Used in the Examples

Material	MVTR grams/100 in ² /24 hrs.	OTR cc/100 in ² /24 hrs.
EVAL EF-F: (15 microns) 85%RH)	6.45 (40°C, 90%RH)	0.03 (20°C, 65%RH)
Urethane: (38 microns) 85%RH)	20.0 (20°C)	---
Nylon, biaxially oriented (25 microns)	10.0 (20°C)	---
	9-10 (40°C, 90%RH)	1.3-2.3 (25°C, atm)
		dry

EXAMPLE 5

Following the procedure in Example 1, a 1.5 mil polyurethane on one side of the 15 micron ethylene vinyl alcohol film and 3.0 mil polyurethane on the other side was prepared.

EXAMPLE 6

Following the procedure in Example 1, a 1.0 mil nylon on one side of the 15 micron ethylene vinyl alcohol film and 0.7 mil ethylene methyl acrylate on the other side was prepared.

EXAMPLE 7

Following the procedure in Example 1, a 1.0 mil nylon on only one side of the 15 micron ethylene vinyl alcohol film was prepared.

EXAMPLE 8

Following the procedure in Example 1, a 0.7 mil polyurethane film on one side of the 15 micron ethylene vinyl alcohol film and a 1.0 mil polyurethane on the other side was prepared.

EXAMPLE 9

Following the procedure in Example 1, a 0.7 mil ethylene methyl acetate on both sides of the ethylene vinyl alcohol film was prepared.

EXAMPLE 10

Following Example 1, a co-extrusion was prepared.

EXAMPLE 11

To an adhesive composition is applied a backing material in any wearable shape of 1-200 cm² surface area and having a thickness of 12 to 175 microns. The backing material is composed of one or

more polymeric layers, joined by any conventional or known means of layering including, but not limited to, lamination, spraying, coating, condensation or coextrusion. The backing is joined to one side of the adhesive transdermal composition.

To release the drug, the preparation is applied to the skin.

EXAMPLE 12

By the method of Example 1, backings, either laminated or coextruded, having 1, 2, 3 or more layers can be prepared as follows:

<u>layer against adhesive</u>	<u>layer 2</u>	<u>layer 3</u>
EVAL EF-F	--	--
EVAL EF-F	Polyurethane	--
Polyurethane	EVAL EF-F	
Polyurethane	EVAL EF-F	Polyurethane
Nylon	EVAL EF-F	--
EVAL EF-F	Nylon	--
Nylon	EVAL EF-F	Polyurethane
Ethylene Methyl Acrylate (EMA)		
EVAL EF-F	--	
EVAL EF-F	EMA	--
EMA	EVAL EF-F	Polyurethane

Wherein the term "EVAL EF-F" refers to a preparation having a thickness of 10 to 25 microns, the polyurethane has a thickness of 5 to 76 microns, the nylon has a thickness of 10 to 51 microns, the EMA has a thickness of 10 to 51 microns.

DETAILED DESCRIPTION OF THE DRAWING

The composition containing the backing in Fig. 1, which composition is generally shown by 10, is comprised of the drug containing carrier layer 14 having the face 12a to be applied to the skin containing an adhesive for adhering to the skin, and

containing a second opposed layer 12b which is attached to the backing 16. The backing 16 shown in Fig. 1 consists of three layers 18, 20 and 22. The optional first layer 18 is the layer where the polymeric material has a high water vapor transmission rate. Intermediate layer 20 is the layer having both a high water vapor transmission rate and a low gas transmission rate, while a third layer 22 is the layer having a high water vapor transmission rate. The optional layer 18 minimizes the passage of the drug contained in matrix 14 to the backing layer, but permits the passage of moisture therefrom. Layer 20 also permits the passage of water vapor but substantially prevents the passage of drug, thus, maintaining the drug within the matrix 14. The optional layer 22 again permits the passage of water vapor to the environment, but by virtue of layer 20 limits access of gas from the environment through the device.

What is claimed is:

1. A composition for the administration of drugs through the skin which comprises:
 - a pharmacologically active agent in a generally planar carrier having two surfaces, one surface being adapted for application to the skin and the second surface opposed thereto; and
 - a backing of flexible material for said second surface of the carrier comprising at least one layer which permits the selective transmission of water vapor from the skin through the composition and into the atmosphere; said flexible material having a water vapor transmission rate about equal to or in excess of that of ethylene vinyl alcohol copolymer and an oxygen transmission rate about equal to or less than that of ethylene vinyl alcohol copolymer, in which the ethylene vinyl alcohol copolymer has a thickness from about 0.2 to 3 mils.
2. The composition of claim 1, having a water vapor transmission rate in excess of 2 to 4 grams per 24 hours per 100 square inches at 40°C and 90% relative humidity.
3. The composition of claim 2 having a second layer in contact with said backing having a water vapor transmission rate about equal to or in excess of that of ethylene vinyl alcohol copolymer.
4. The composition of claim 3 having layer in which the second layer has a water vapor transmission rate equal to or in excess of about 6 grams per 24 hours per 100 square inches, at 40°C at 90% relative humidity.

SUBSTITUTE SHEET

5. The composition of claim 3, having a third layer in contact with said backing having a water vapor transmission rate in excess of that of ethylene vinyl alcohol copolymer.

6. The composition of claim 5, in which said second and third layers have water vapor transmission rates in excess of 9 grams per 24 hours per 100 square inches at 40°C and 90% relative humidity.

7. The composition of claim 2, in which the backing is ethylene vinyl alcohol copolymer has a water vapor transmission rate in excess of about 6 grams per 24 hours per 100 inches at 40°C and 90% relative humidity and an oxygen transmission rate below about 0.1 cubic centimeters per 100 square inches per 24 hours at 1 atmosphere pressure, 20°C, and 65% relative humidity and a second layer of a polyurethane, having a water vapor transmission rate in excess of 6 grams under said conditions.

8. The composition of claim 7, having a third layer of polyurethane having a water vapor transmission rate in excess of 9 grams per 24 hours per inch at 40°C and 90% relative humidity.

9. The method for permitting the evaporation of water from a composition for administration of drugs through the skin, which comprises the application to such composition of a backing which permits the selective transmission of water vapor without the transmission of the drug, which comprises the use on such composition of a backing material having a water vapor transmission rate in excess of about 2 to 4 grams per 24 hours per square inch at 40°C and 90% relative humidity and a gas transmission rate of less than 0.1 cubic centimeters per square 100 inches per 24 hours at 1 atmospheric pressure, 20°C and 65% relative humidity.

1/1

FIG. 1

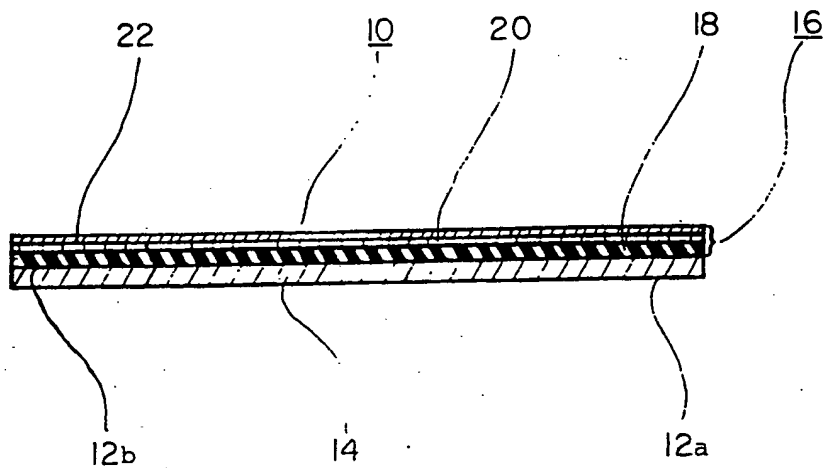

INTERNATIONAL SEARCH REPORT

International Application No PCT/US 90/00241

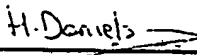
I. CLASSIFICATION OF SUBJECT MATTER (if several classification symbols apply, indicate all) *				
According to International Patent Classification (IPC) or to both National Classification and IPC				
IPC ⁵ : A 61 L 15/44				
II. FIELDS SEARCHED				
Minimum Documentation Searched ⁷				
Classification System	Classification Symbols			
IPC ⁵	A 61 L			
Documentation Searched other than Minimum Documentation to the Extent that such Documents are Included in the Fields Searched ⁸				
III. DOCUMENTS CONSIDERED TO BE RELEVANT ⁹				
Category ⁹	Citation of Document, ¹¹ with indication, where appropriate, of the relevant passages ¹²	Relevant to Claim No. ¹³		
A	Patent Abstracts of Japan, volume 8, no. 110 (C-224)(1547), 23 May 1984 & JP, A, 5925319 (NITTO DENKI KOGYO K.K.) 9 February 1984 see the abstract --	1-9.		
A	Chemical Abstracts, volume 94, no. 14, April 1981, (Columbus, Ohio, US), L. Stanoeva et al.: "Physicomechanical characteristics of films for aerosol use", see page 393, abstract 109245a & FARMATSIYA (SOFIA) 1980, 30(4), 29-33 --	1		
A	EP, A, 0272987 (CYGNUS RESEARCH CORPORATION) 29 June 1988 see page 3, lines 51-65; page 4, lines 1-3; claims 1,8-9 -----	1		
<table style="width: 100%; border: none;"> <tr> <td style="width: 50%; border: none; vertical-align: top;"> <p>¹⁰ Special categories of cited documents:</p> <p>"A" document defining the general state of the art which is not considered to be of particular relevance</p> <p>"E" earlier document but published on or after the international filing date</p> <p>"L" document which may throw doubts on priority claim(s) or which is cited to establish the publication date of another citation or other special reason (as specified)</p> <p>"O" document referring to an oral disclosure, use, exhibition or other means</p> <p>"P" document published prior to the international filing date but later than the priority date claimed</p> </td> <td style="width: 50%; border: none; vertical-align: top;"> <p>"T" later document published after the international filing date or priority date and not in conflict with the application but cited to understand the principle or theory underlying the invention</p> <p>"X" document of particular relevance; the claimed invention cannot be considered novel or cannot be considered to involve an inventive step</p> <p>"Y" document of particular relevance; the claimed invention cannot be considered to involve an inventive step when the document is combined with one or more other such documents, such combination being obvious to a person skilled in the art.</p> <p>"&" document member of the same patent family</p> </td> </tr> </table>			<p>¹⁰ Special categories of cited documents:</p> <p>"A" document defining the general state of the art which is not considered to be of particular relevance</p> <p>"E" earlier document but published on or after the international filing date</p> <p>"L" document which may throw doubts on priority claim(s) or which is cited to establish the publication date of another citation or other special reason (as specified)</p> <p>"O" document referring to an oral disclosure, use, exhibition or other means</p> <p>"P" document published prior to the international filing date but later than the priority date claimed</p>	<p>"T" later document published after the international filing date or priority date and not in conflict with the application but cited to understand the principle or theory underlying the invention</p> <p>"X" document of particular relevance; the claimed invention cannot be considered novel or cannot be considered to involve an inventive step</p> <p>"Y" document of particular relevance; the claimed invention cannot be considered to involve an inventive step when the document is combined with one or more other such documents, such combination being obvious to a person skilled in the art.</p> <p>"&" document member of the same patent family</p>
<p>¹⁰ Special categories of cited documents:</p> <p>"A" document defining the general state of the art which is not considered to be of particular relevance</p> <p>"E" earlier document but published on or after the international filing date</p> <p>"L" document which may throw doubts on priority claim(s) or which is cited to establish the publication date of another citation or other special reason (as specified)</p> <p>"O" document referring to an oral disclosure, use, exhibition or other means</p> <p>"P" document published prior to the international filing date but later than the priority date claimed</p>	<p>"T" later document published after the international filing date or priority date and not in conflict with the application but cited to understand the principle or theory underlying the invention</p> <p>"X" document of particular relevance; the claimed invention cannot be considered novel or cannot be considered to involve an inventive step</p> <p>"Y" document of particular relevance; the claimed invention cannot be considered to involve an inventive step when the document is combined with one or more other such documents, such combination being obvious to a person skilled in the art.</p> <p>"&" document member of the same patent family</p>			
IV. CERTIFICATION				
Date of the Actual Completion of the International Search	Date of Mailing of this International Search Report			
27th April 1990	07.06.90			
International Searching Authority	Signature of Authorized Officer			
EUROPEAN PATENT OFFICE	<div style="display: flex; justify-content: space-between;"> <div style="text-align: center;">  H. DANIELS </div> <div style="text-align: center;"> H. DANIELS </div> </div>			

**ANNEX TO THE INTERNATIONAL SEARCH REPORT
ON INTERNATIONAL PATENT APPLICATION NO.**

US 9000241
SA 34289

This annex lists the patent family members relating to the patent documents cited in the above-mentioned international search report. The members are as contained in the European Patent Office EDP file on 22/05/90. The European Patent Office is in no way liable for these particulars which are merely given for the purpose of information.

Patent document cited in search report	Publication date	Patent family member(s)	Publication date
EP-A- 0272987	29-06-88	AU-A- 8249887 JP-A- 63233916	23-06-88 29-09-88

EP/FORM 60079

For more details about this annex : see Official Journal of the European Patent Office, No. 12/82